



HPP External Hydraulic Power Pack

A compact and portable hydraulic power pack.

Features

- Compact and portable
- Up to 4 hydraulic circuits
- Simple interface to RM350 Series gas controllers or other control means
- 25L oil tank
- Oil temperature and level switches

Configurations

- Hydraulic pump output pressure max 180 Bar (2,610 psi)
- Available range: 5 Bar to 180 Bar (72.5 psi to 2,610 psi).
- Hydraulic pump output flow rate 4.2 lpm (65 US gph)
- Tank capacity: 25L (1.56 US Gallons)
- Motor power: 1.3kW (1.74 HP)
- Motor speed: 1,450 rpm (50Hz), 1760 rpm (60Hz)
- Solenoid valve coil voltage: 24 v dc
- Full load current: std: 2.5A

PA: 5.1A

PB: 2.0A

Ordering information

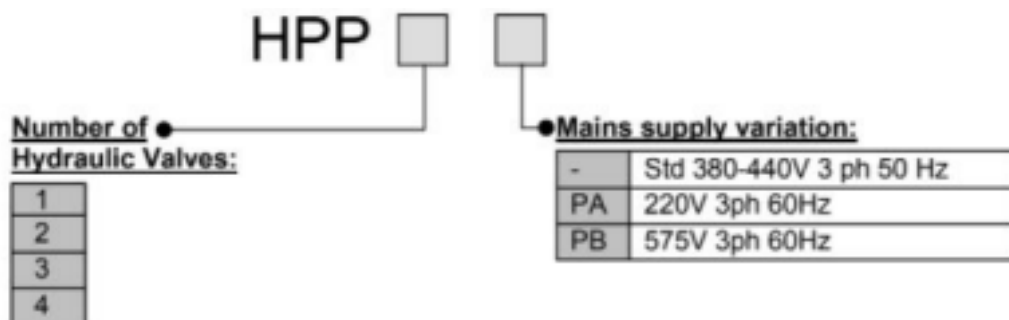

Schematic:

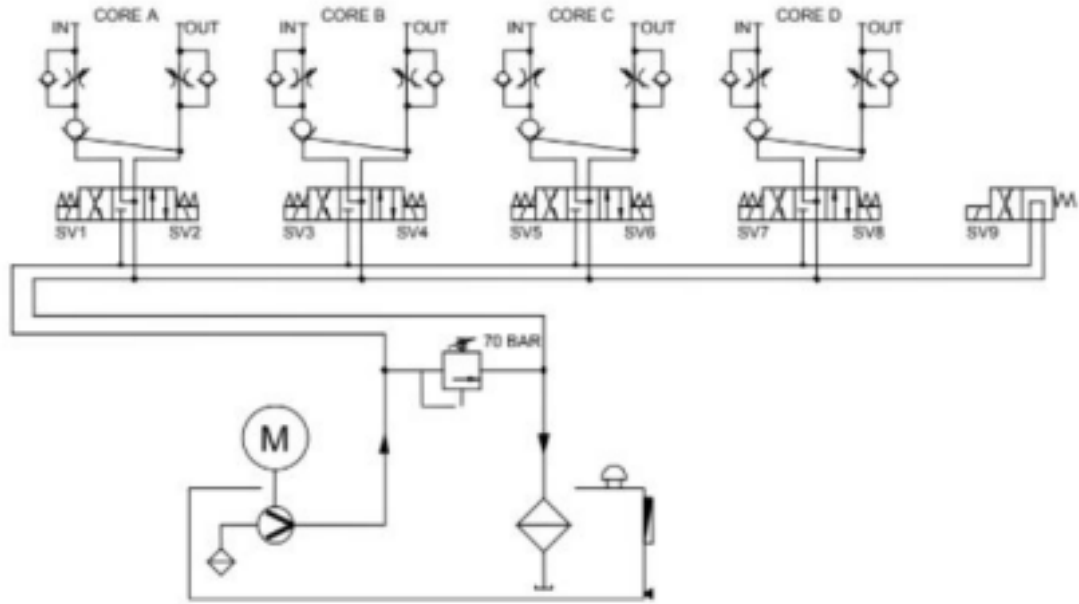

Dimensions:

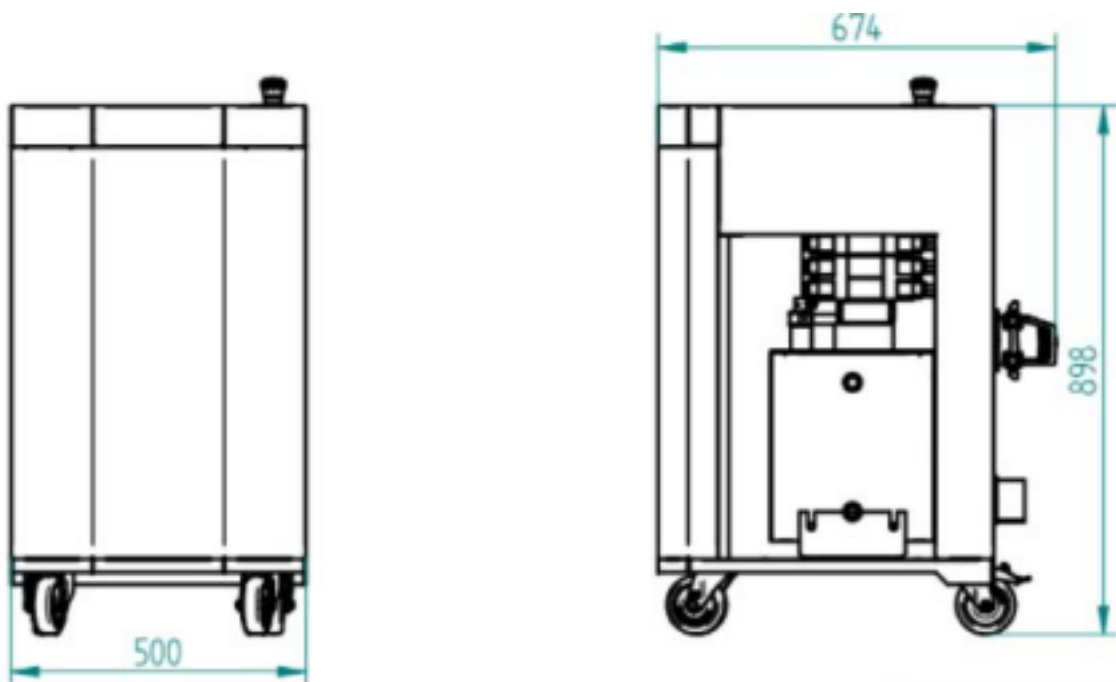

Disclaimer: Data is provided for information and may be subject to change.